

UNTERFLURAUSSZÜGE

mit Push open
with push open

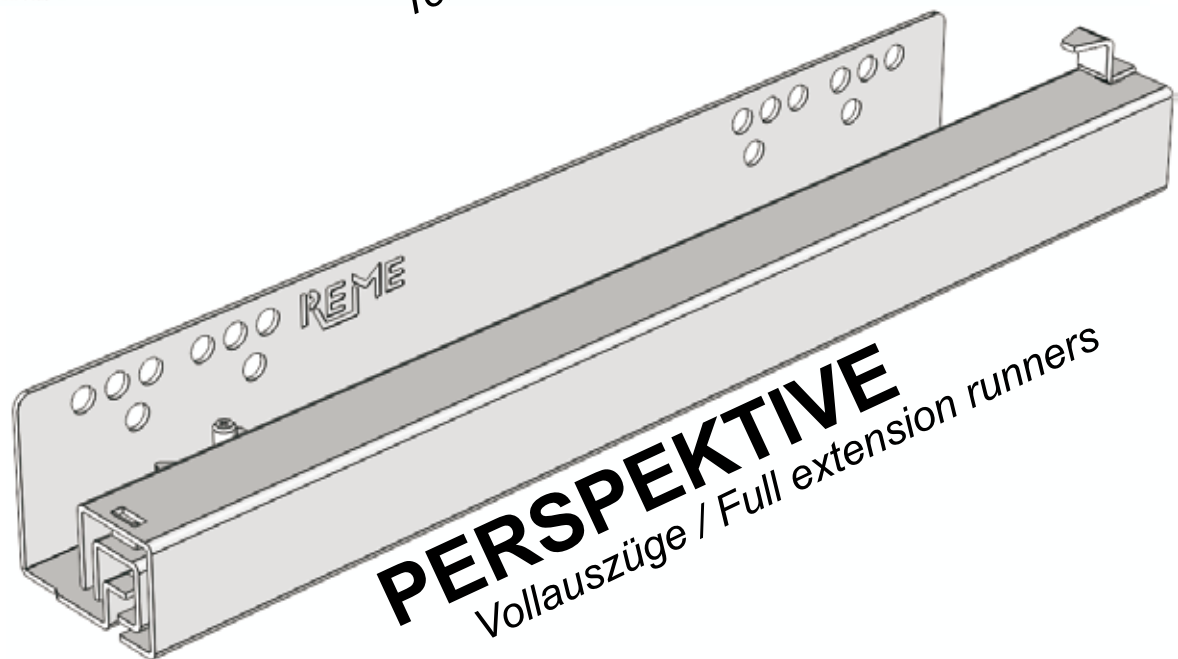

REME



Standardabmessungen Standard dimensions

In den Einbaubreiten identisch.
Installation-width identical.

FORTUNA

Teilauszug mit Push open
Part extension runner with push open

Bestell-Nr.	Schubkastentiefe	Länge Schubkastenschiene	Länge Korpussschiene
Order-No.	Drawer depth	Length drawer runner	Length runner track
025 03	250	251,5 mm	214 mm
030 03	300	301,5 mm	246 mm
032 03	325	326,5 mm	246 mm
035 03	350	351,5 mm	246 mm
040 03	400	401,5 mm	278 mm
045 03	450	451,5 mm	310 mm
050 03	500	501,5 mm	342 mm
055 03	550	551,5 mm	342 mm

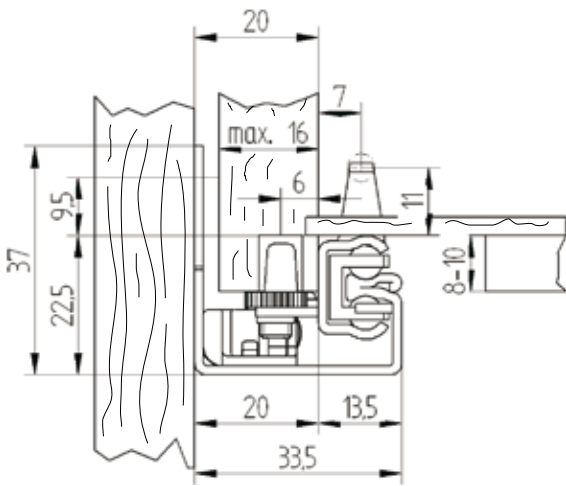

Bohrungen und Ausstanzungen im Schubkasten
Drill-holes and punches within the drawer

für Teilauszüge
for part extension runners

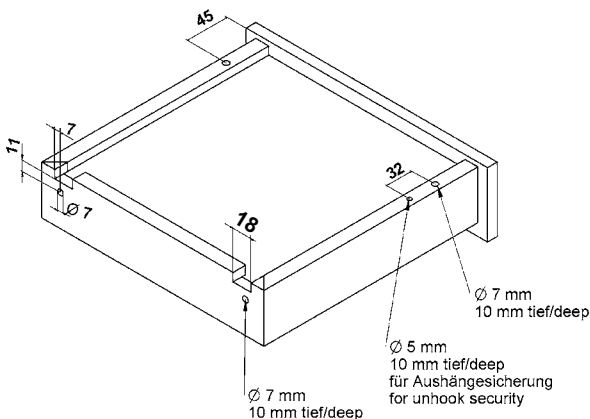

Aushängesicherung
Unhook security

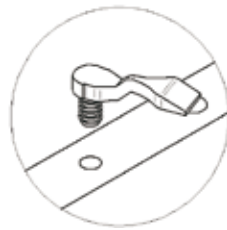

PERSPEKTIVE

Vollauszug mit Push open
Full extension runner with push open

Bestell-Nr.	Schubkastentiefe	Länge Schubkastenschiene	Länge Korpussschiene
Order-No.	Drawer depth	Length drawer runner	Length runner track
026 04	250	260 mm	214 mm
031 04	300	310 mm	278 mm
033 04	325	335 mm	278 mm
036 04	350	360 mm	278 mm
041 04	400	410 mm	278 mm
046 04	450	460 mm	342 mm
051 04	500	510 mm	342 mm
056 04	550	560 mm	342 mm

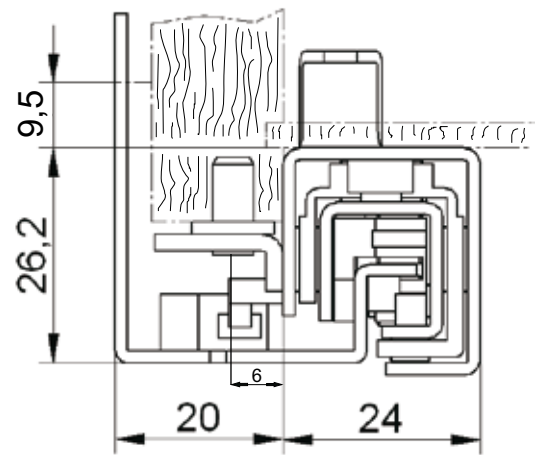

Bohrungen und Ausstanzungen im Schubkasten
Drill-holes and punches within the drawer

für Vollauszüge
for full extension runners

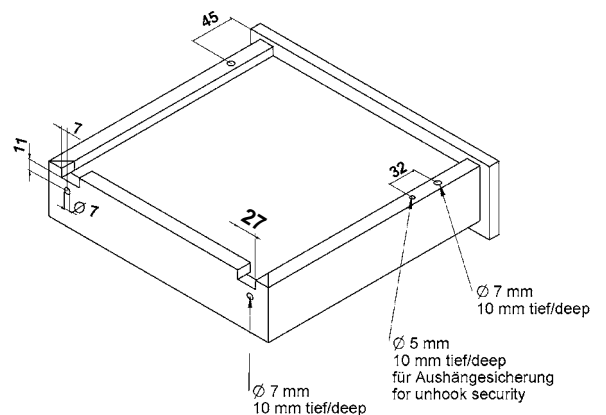

F fortuna

Teilauszug mit Push open
Part extension runner with push open



Werkstoff: verzinktes Stahlblech
Materialdicke: 1,50 mm
Belastbarkeit: 25 kg
Verpackung: 35 Stück pro Karton

Material: galvanised sheet steel
Material thickness: 1,50 mm
Carrying capacity: 25 kg
Packaging: 35 pieces per carton



Längen und Lochbild der Korpusschienen Length and punch illustration of the runner tracks

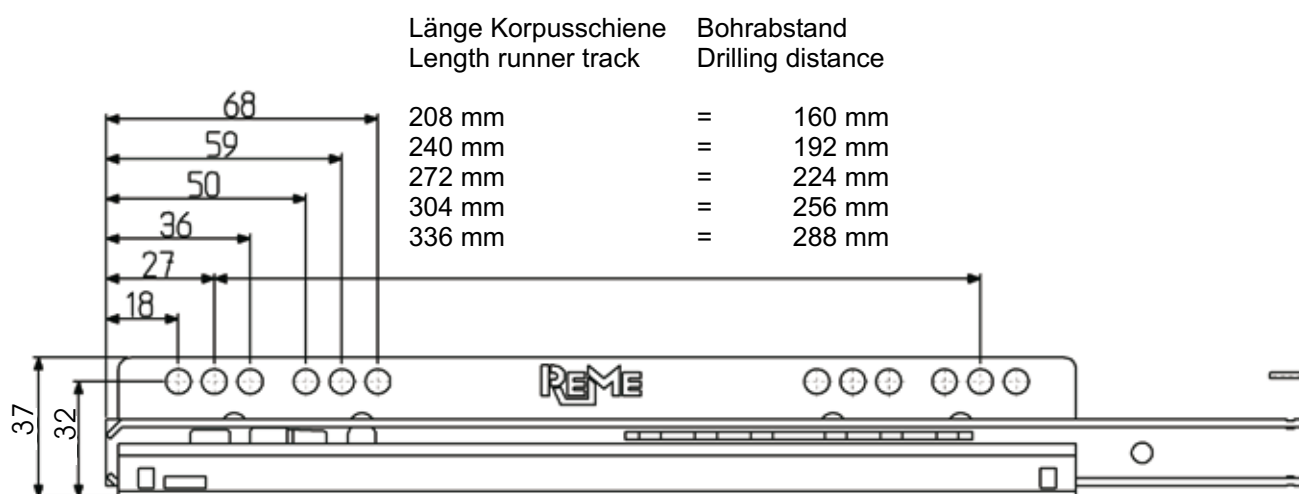

Ermittlung der Schubkastenbreite Ascertainment the drawer width

Einbaumaße Build-in dimensions

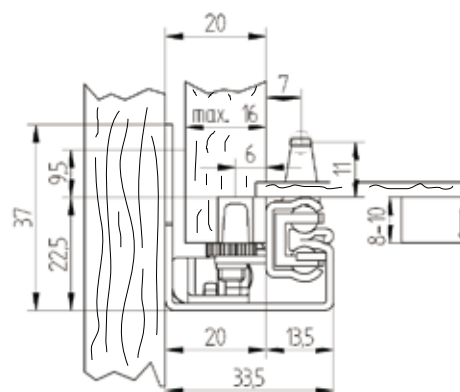
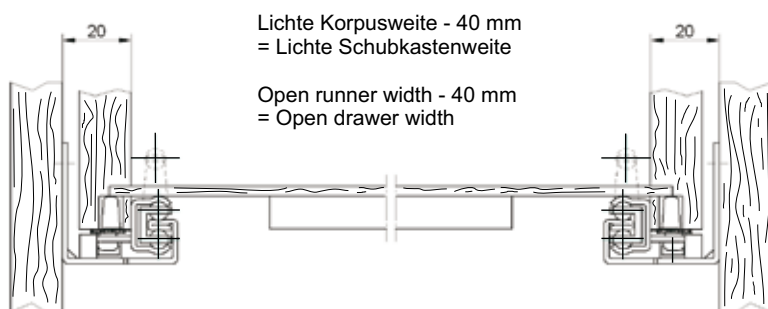

Perspektive

Vollauszug mit Push open
Full extension runner with push open



Werkstoff: verzinktes Stahlblech
Materialdicke: 1,50 mm
Belastbarkeit: 30 kg
Verpackung: 25 Stück pro Karton

Material: galvanised sheet steel
Material thickness: 1,50 mm
Carrying capacity: 30 kg
Packaging: 25 pieces per carton

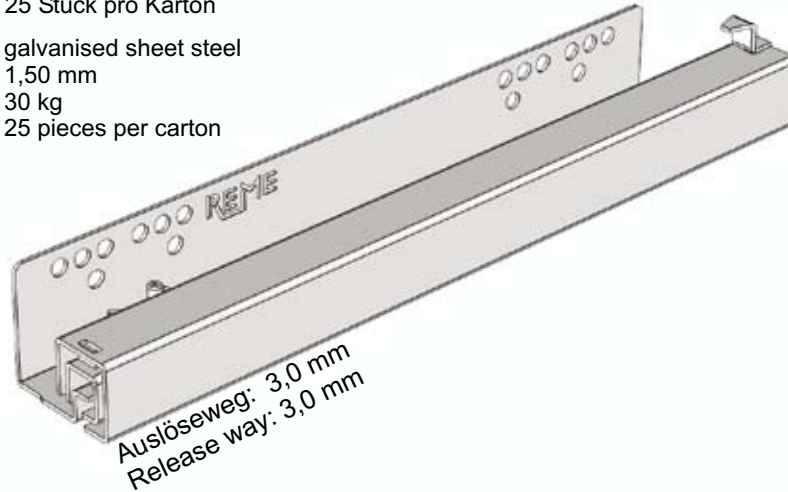

Lochbild der Korpuschienen
Punch illustration of the runner tracks

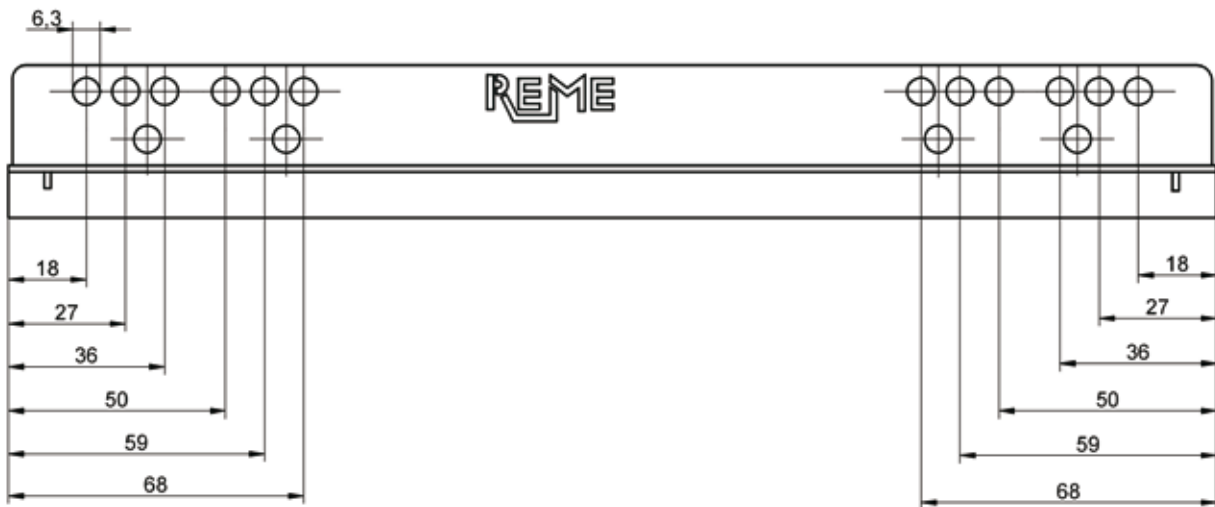

Ermittlung der Schubkastenbreite
Ascertainment the drawer width

Einbaumaße
Build-in dimensions

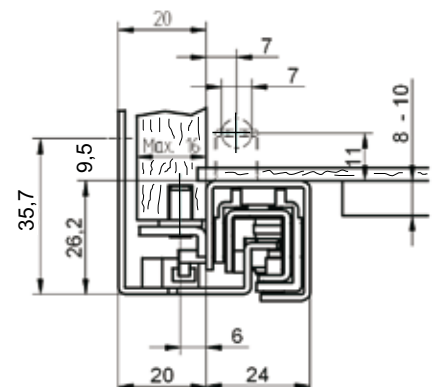
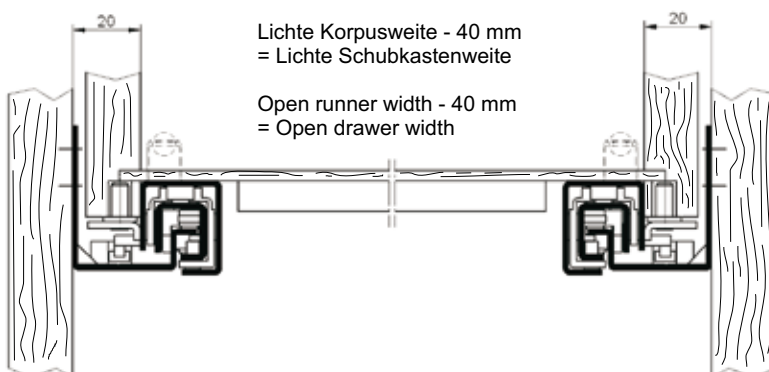

A nfahrt Directions

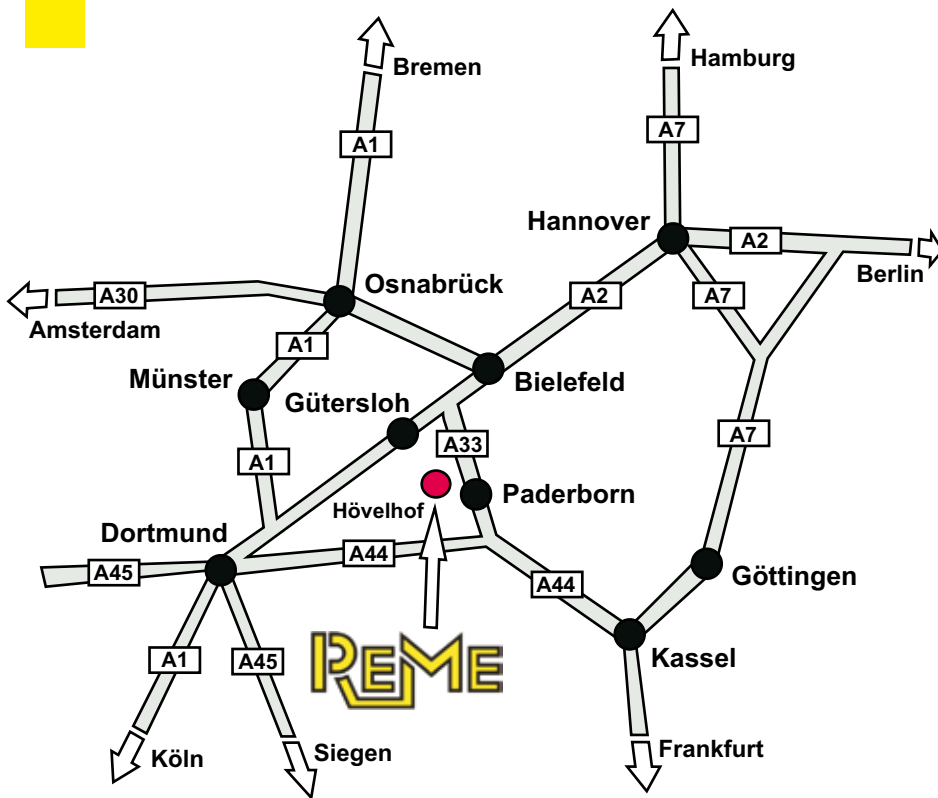

Entfernung Flughäfen

Distance airports

Paderborn	25 km
Münster	100 km
Dortmund	105 km
Hannover	130 km
Köln	200 km
Düsseldorf	210 km
Frankfurt	300 km

Sie erreichen uns:

Autobahn A2 Dortmund - Hannover, Abfahrt Kreuz Bielefeld A33 Richtung Paderborn, Abfahrt Stukenbrock-Senne/Hövelhof(23)B68 Richtung Hövelhof.

Autobahn A44 Kassel - Dortmund, Abfahrt Wünnenberg - Haaren A33 Richtung Bielefeld, Abfahrt Stukenbrock-Senne/Hövelhof(23)B68 Richtung Hövelhof.

How to find us:

Motorway A2 Dortmund - Hannover, at motorway intersection Bielefeld onto A33 towards Paderborn, exit Stukenbrock - Senne/Hövelhof(23)B68 towards Hövelhof.

Motorway A44 Kassel - Dortmund, exit Wünnenberg - Haaren A33 towards Bielefeld, exit Stukenbrock - Senne/Hövelhof(23)B68 towards Hövelhof.



Werk II Otto-Hahn-Straße 17

REME
Möbel-Beschläge

Industriestraße 48
33161 Hövelhof
Telefon ++49 (0) 5257 9780-0
Telefax ++49 (0) 5257 9780-20
E-Mail info@reme-gmbh.de
Web www.reme-gmbh.de